

CONSTIX™ Swab, SP-10

Double layer sealed knit polyester

Description

CONSTIX SP-10 sealed polyester swab consists of 100% knit polyester fabric that's thermally bonded to a flex-tip polypropylene handle. The cleanroom laundered, double layer knit polyester head provides enhanced sorbency, particle entrapment and removal. The polyester head is constructed without adhesives or binders, which makes the swab compatible with most common solvents, such as alcohols and ketones. The polypropylene handle has a thin, flexible tip that enables access to very small areas and components. The swab is durable, absorbent and features extremely low particles and residue levels.

Technical Data

Swab head material	Knit polyester
Swab handle material	Polypropylene
Construction	Thermally sealed and attached

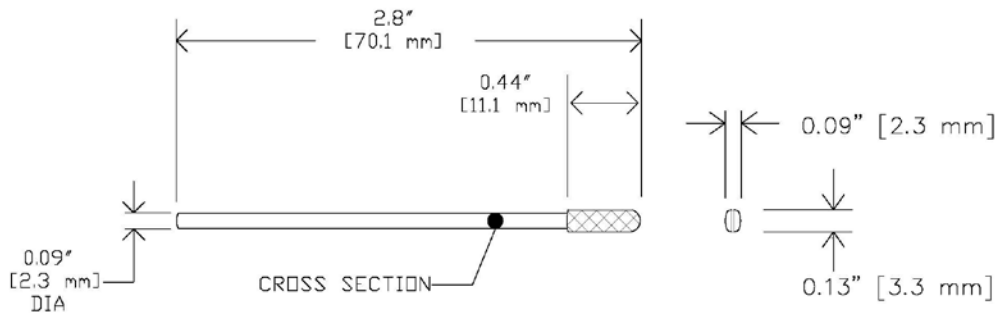

Notes:

- 1) Data shown are typical values and should not be used as product specifications.
- 2) Valid product comparisons may only be obtained through side-by-side testing in the same test facility, under similar conditions.
- 3) Current and/or comparison data may be available. Please contact a Contec sales representative for details.

Revision date: 02/23/17



Copyright © 2017 Contec, Inc. All rights reserved.

North America
 P.O. Box 530
 Spartanburg, SC 29304 USA
 Phone: +1-864-503-8333
 www.contecinc.com

Europe
 ZI du Prat – RP 3707
 56037 VANNES Cedex
 FRANCE
 +33 297 437 698

China
 No.17 Longyun Road
 Suzhou 215024
 CHINA
 + 86-512-6274 4050