

CODE 12101104	DESCRIPTION: OVERALL MAO COLLAR IN PLP 50 gr BLUE ANTISTATIC + INTERNAL POCKET
	PACKAGING 25 pcs – single bag

Picture model and size

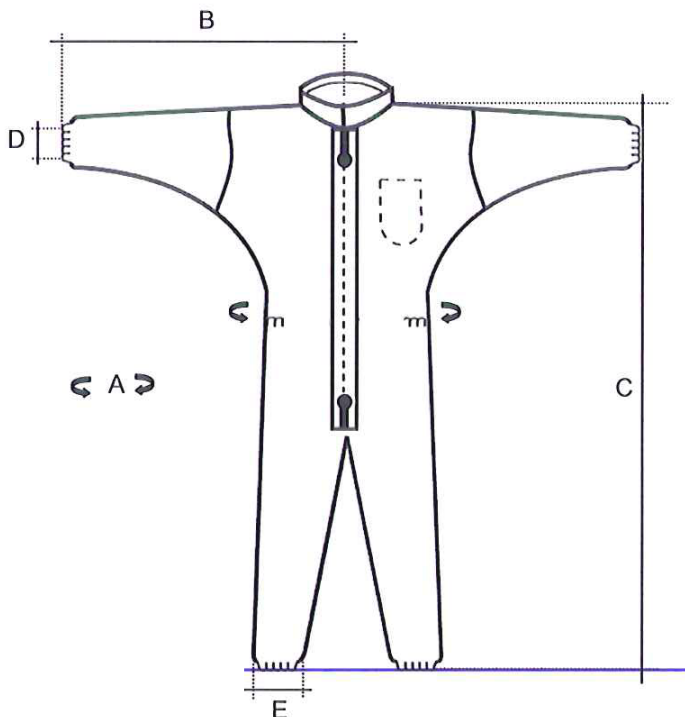

Size label bag

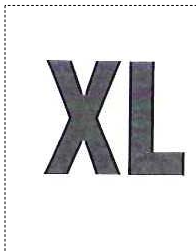

	S	M	L	XL	XXL	XXXL
A	114	120	128	136	144	144
B	82	86	90	94	98	102
C	156	162	168	174	180	186
D	16	16	16	18	20	20
E	26	26	26	27	27	27

+/- 2 cm
+/- 1 cm
+/- 3 cm
+/- 1 cm
+/- 1 cm

Garment neck size label

INDUTEX
POLIGARD
PLP 50 gr.

CE DATE:
09/13

EN 1149-1

182/188
LOT
108/116

SIZE XL

CATEGORY 1

INDUMENTO MONOUSO
DO NOT RE-USE
VETEMENT A USAGE UNIQUE
EINWEG-KLEIDUNGSSTUECK
INDUMENTO MONO DESECHABLE

Carton label

18034058037625



PLP 50 GR. ANT.
BLU - BLEU - BLUE - BLAU

OVERALLS-TUTE-KOMBI-COMBINAISONS

-COLLO COREANA - TASCA - ELASTICO POLSI + VITA + CAVIGLIE
-COL MAO - POCHE - ELASTIQUE POIGNETS +TAILLE + CHEVILLES
-MAO COLLAR - POCHE - ELASTIC WRISTS + WAIST + ANKLES
-STEHKRAGEN-TASCHE-GZUG HANDGELENKE+TAILLE+FESSELN

MADE IN



12101104

25 PCS 4/XL LOT.

000000

Emissione: RS 

Verifica: PRO 

Verifica: CQ 

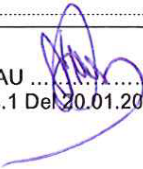
Approv: AU 
Mod-09.06 Vers.1 Del 20.01.2000